

ALEKO® Indoor Sauna

www.AlekoProducts.com

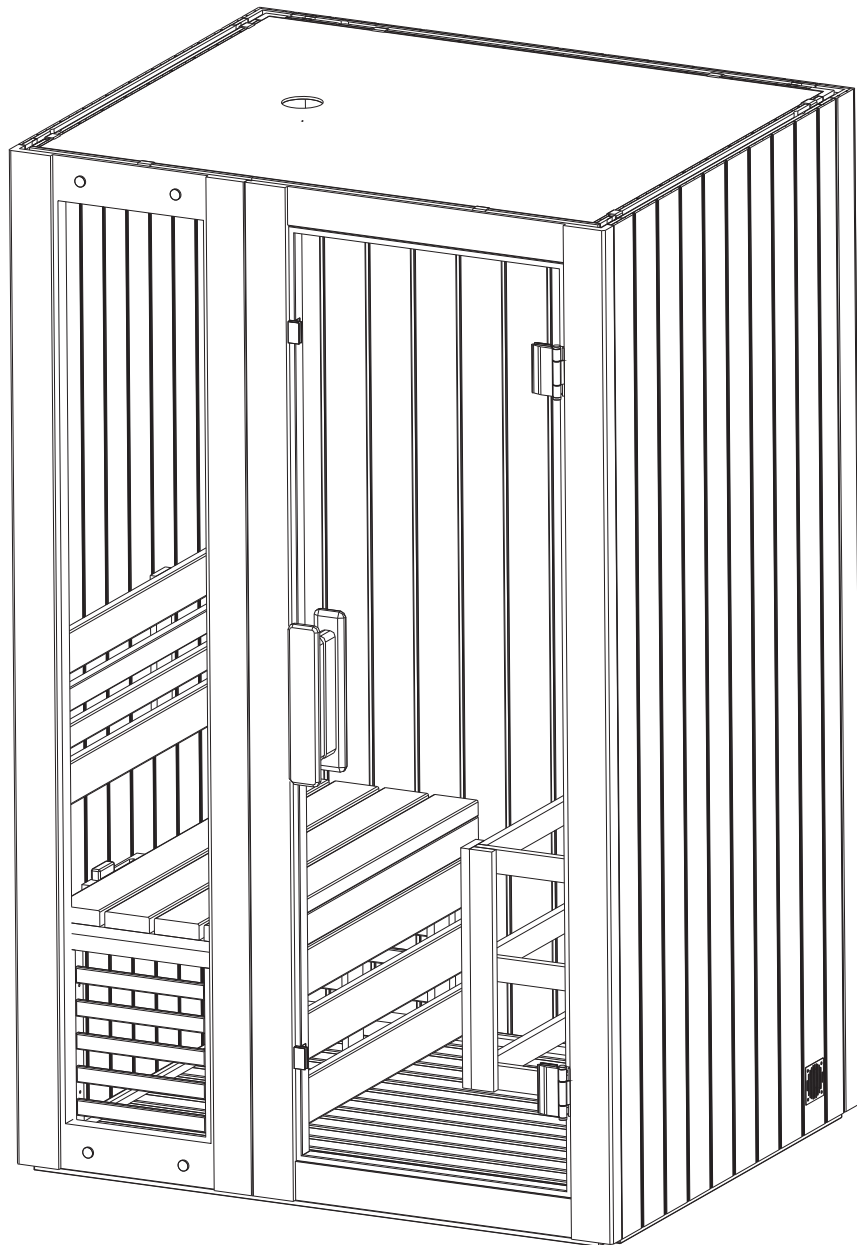

User's Manual for 2-Person Sauna

Introduction:

Read before install:





- (1)The sauna room must be installed by at least two people together.
- (2)About installation position: check whether floor or platform is horizontal. Slight slope will not affect installation and use of the sauna room. But a spacer is needed to keep the sauna room horizontal if there is an obvious slope.
- (3)All screw heads installed in the sauna room have to be completely plugged into the wood in case of burns. If you want to install accessories that not provided by us, please try to avoid metal accessories, or you can do relevant thermal insulation treatment for the accessories.
- (4)As there are electrical components in the sauna room, please ask qualified electrician for installation.

1. Tools

Rubber hammer ×1



2. Tools needed

Electric drill × 1	Measuring tape × 1	Spirit level x 1	Pencil x 1
			

3. Configuration list

Basic configuration				
No.	Name	Dimension	Unit	Ref.
				TC2/TH2
1	Sauna heater (recommended)		Pc	3kw/1
2	4L bucket		Pc	1
3	Sauna stone		kg	20
4	Thermometer and hygrometer		Pc	1
5	Ladle		Pc	1
6	Glue		Pcs	2

Components list

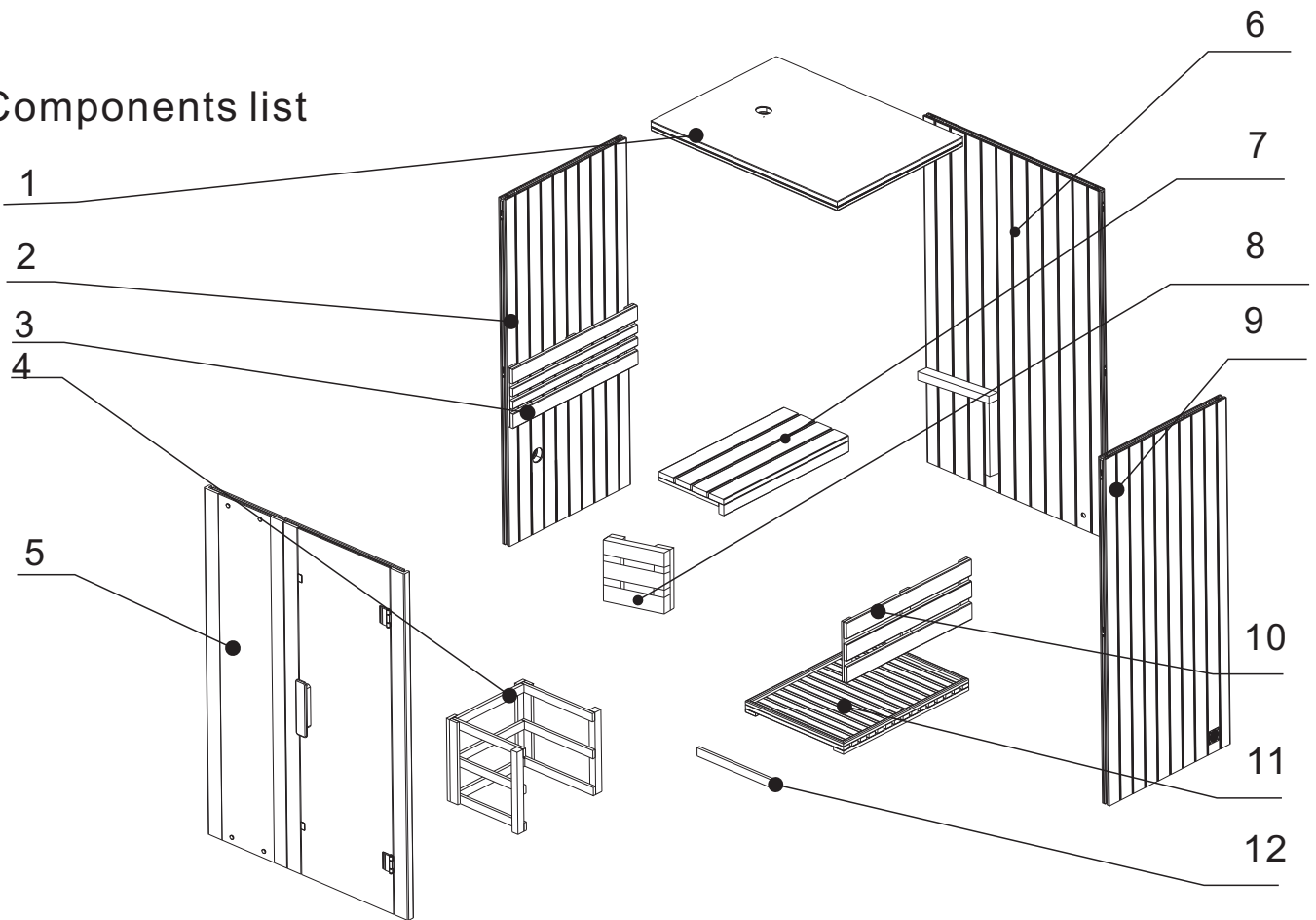

S/N	Name	Quantity
1	Top panel	1
2	Left wall	1
3	Backrest	1
4	Heater fence	1
5	Front wall	1
6	Back wall	1
7	Bench panel	1

S/N	Name	Quantity
8	Bench feet	1
9	Right wall	1
10	Decorating fence of bench	1
11	Bottom board	1
12	Bottom connection bar	1

Installation steps for sauna room:

- 1、 Back wall installation····· 4
- 2、 Front wall installation····· 5
- 3、 Top panel installation····· 5
- 4、 Bottom board installation····· 6
- 5、 Bench and backrest installation····· 6
- 6、 Heater fence installation····· 7
- 7、 Other components installation····· 7
- 8、 Sketch after installation····· 8
- 9、 Uses and recommendations····· 9

Tools:



1、 Back wall installation

1-1 : Back wall components

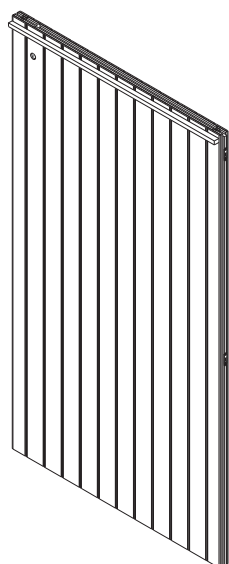

Hold up the back wall

1-2: Hold up the left and right walls, making it 90° connecting vertically with the back wall.

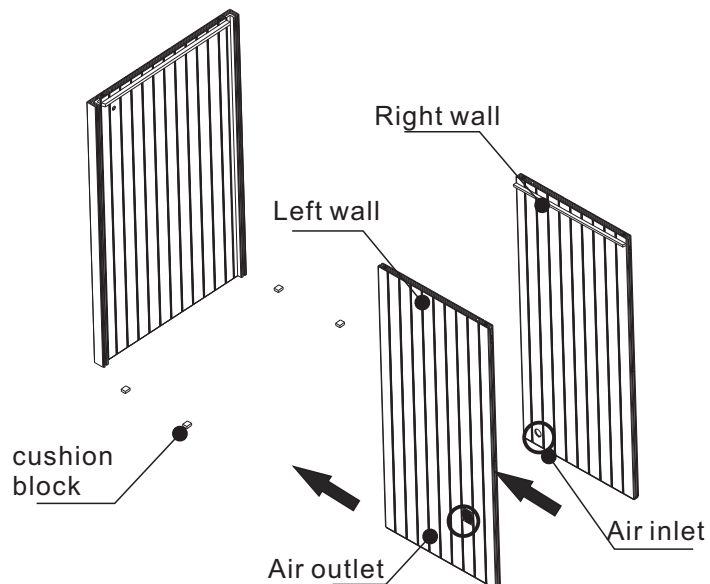

Note: After it is connected and when the installation is difficult to complete, use the glue hammer to tap for adjustment.

1-3: Install the lock catch of the back wall and left and right walls.

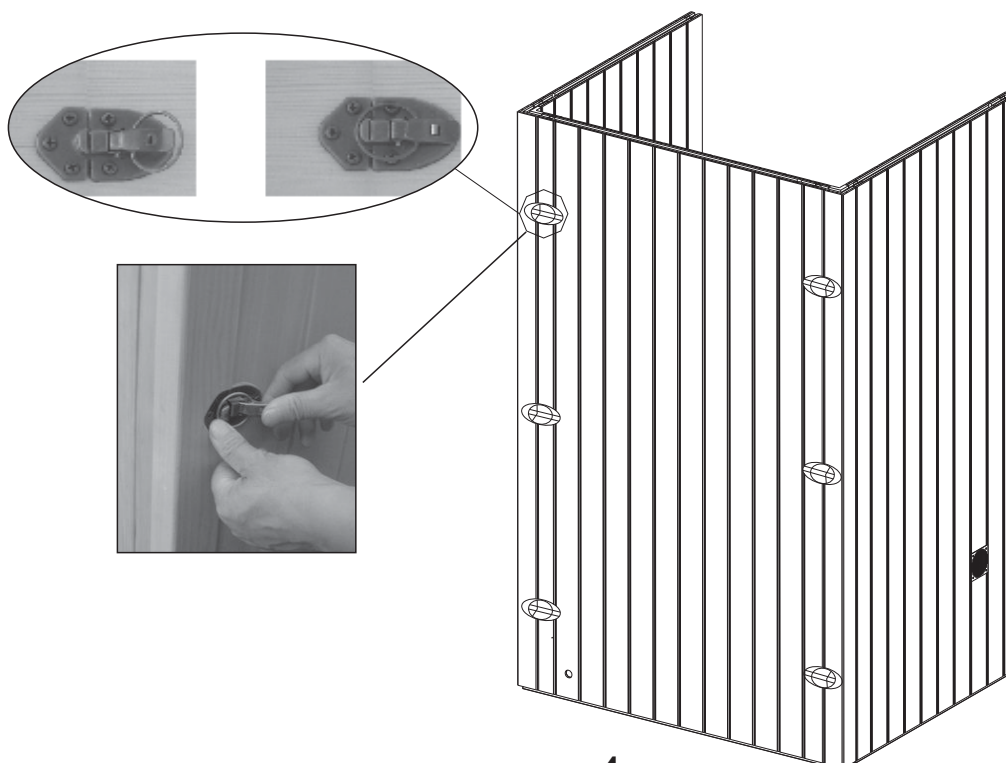

2. Front wall installation

2-1: Front wall installation.

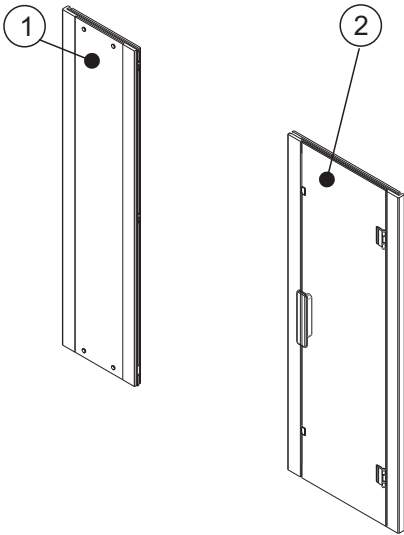

- 1. Fixed glass window
- 2. Switch glass door

2-2: Install and fixed glass window .

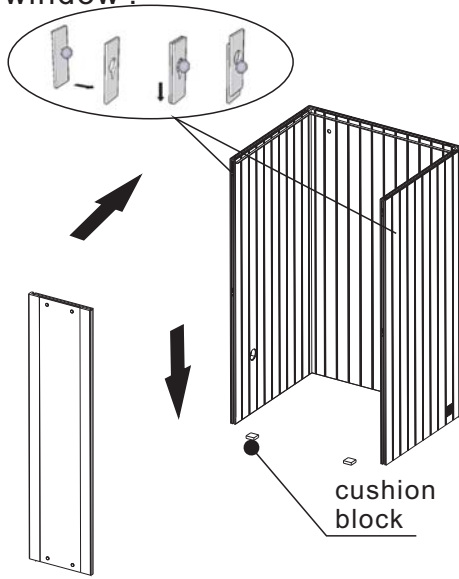

Connect and fix with the hidden catch of the glass window and on the left wall.

2-3: Install the switch glass door, making it align with the hidden catch of the fixed glass window and the right wall

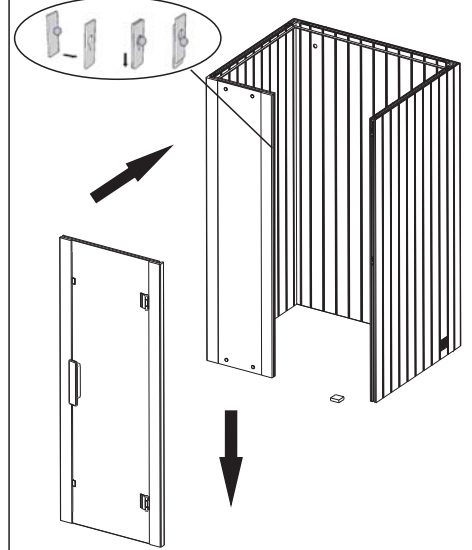

Note: After it is connected and when the installation is difficult to complete, use the glue hammer to tap for adjustment.

3. Top panel installation

3-1: Installation figure of top panel

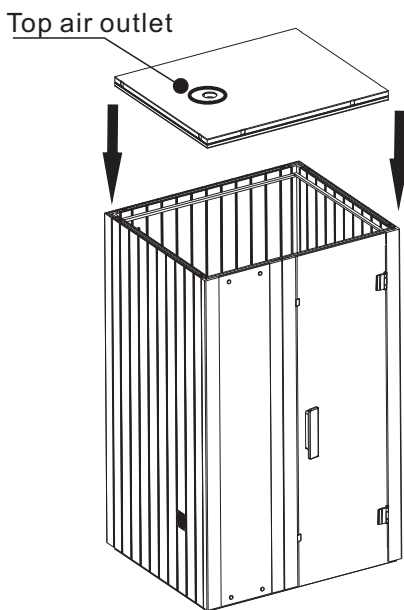

3-2: Fix top panel around with screws

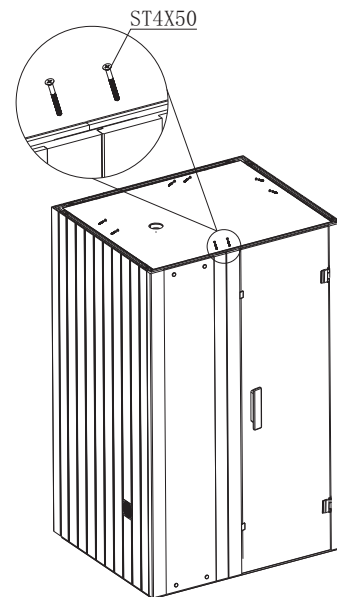

4、 Bottom board installation

Check whether the ground is flat before installation. Please install it on flat ground.

4-1: Firstly install the bottom connection bar, then the bottom footboard.

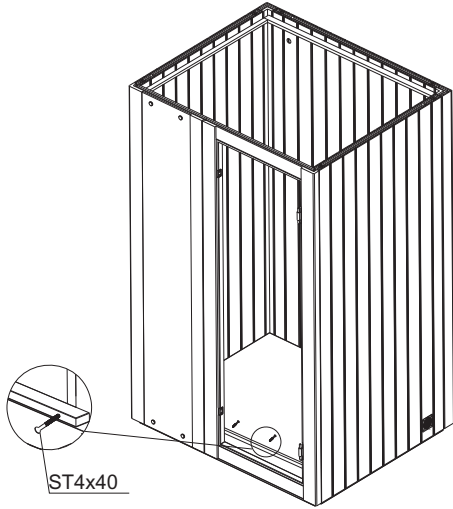

4-2: Install the bottom footboard under the bottom connection bar.

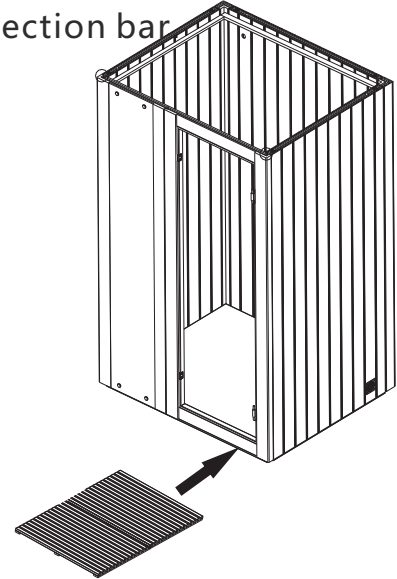

5. Bench and backrest installation

5-1: First install the bench feet, then the bench board.

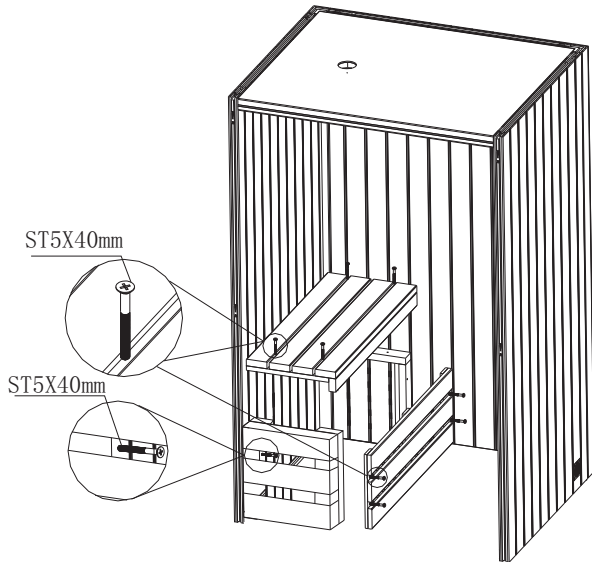

5-2: Installation figure of backrest.

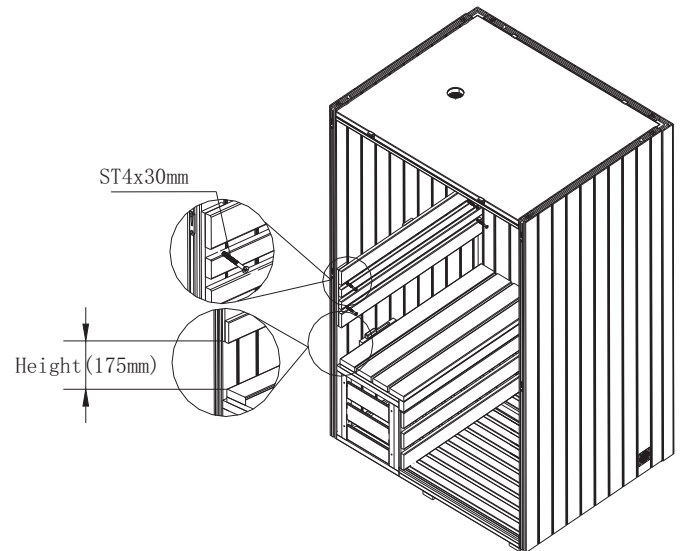

6.Heater fence installation

6-1: Heater fence installation

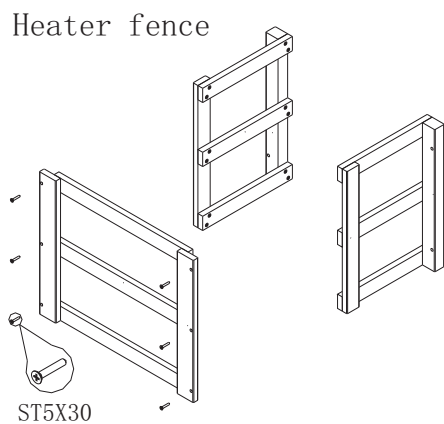

6-2: Installation figure of heater fence

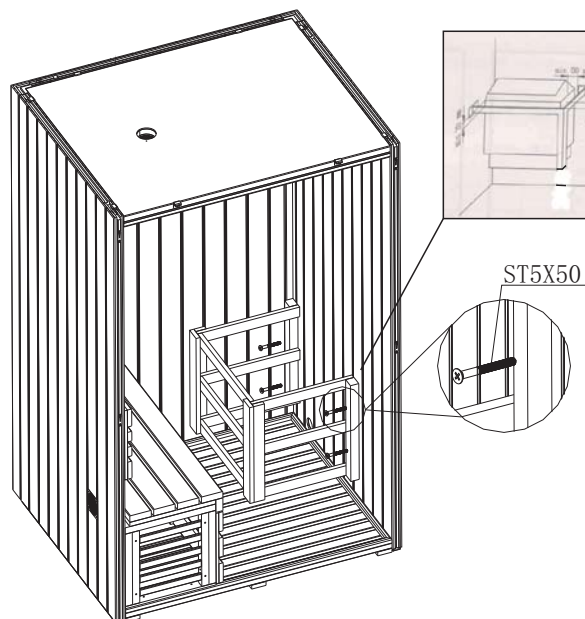

Note: When the stove is installed on the wall beyond the ground, and the fence shall be raised up with the stove. The details are shown in the above figure.

7.Other accessories installation

7-1: Sketch of anti-explosive lamp holder

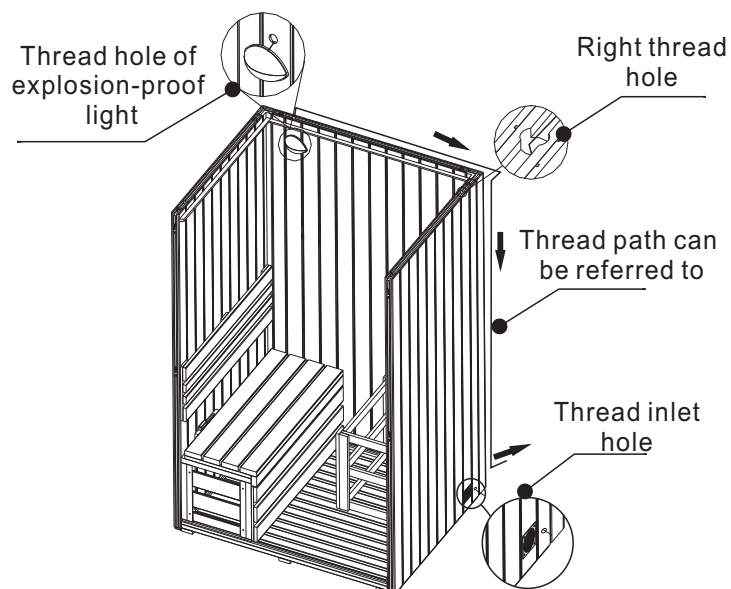

The lamp line can be led along the lamp line tube. The user can adjust the time it leads out from the bottom according to the real situation.

Sketch after installation

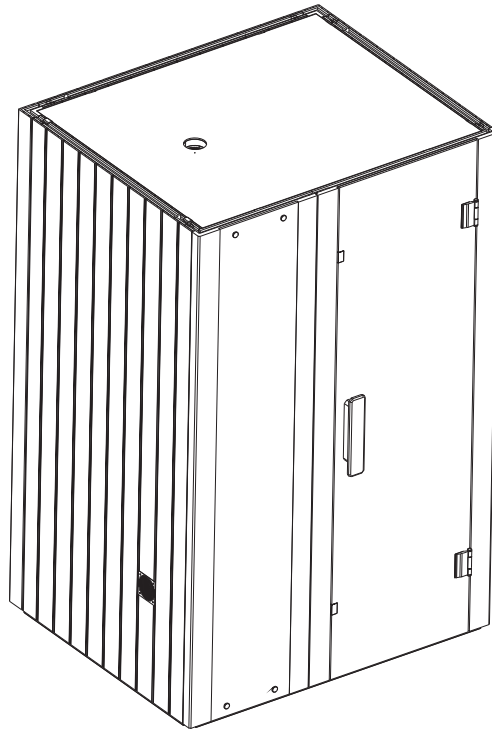

IX. Instructions on use, maintenance and attentions:

Use:

- (1) Start the sauna heater, set the constant controller at the temperature you need, turn on the switch to preheat it for 30-60 minutes, and the temperature is usually recommended 60°C-80°C (area from stool to head). For the first use, start from a lower temperature, and then adjust it according to how your body can withstand (generally speaking, it is 80-85°C for dry steaming, and can also be higher, while it is usually 45-60°C for wet steaming(in the steam room)).
- (2) The difference between "dry steaming" and "wet steaming": "dry steaming" demands no labbering on hot sauna stone to make room humidity less than 10%. If you dislike dry steaming, you choose books you like to read, which allows you to enjoy in the atmosphere of sauna. "Wet steaming" demands high humidity which is over 35%. Most customers prefer wet steaming, for it performs very well in steam shock, erasing fatigue, cleaning the skin and waste in bodies, thus benefiting both the body and the spirit.
- (3) Before entering the sauna, please take off clothes, put down glasses, jewelries, mobile phones and other things, and then take a simple shower or bath.
- (4) It is usually 5-15 minutes every time.
- (5) After entering the sauna, you can soak in the swimming pool, wipe your body with snow, and take a shower to cool your body for 10-20 minutes.
- (6) The so called "steam shock" refers to the special environment human bodies can stand formed by increasing heat in the wooden house because of a lot of steam after you labber on the high temperature stone in the sauna heater.
- (7) If you re-enter the sauna room, you may find there are droplets on the sauna stone condensed from steam. If water overflows from the heater to the ground, it means you have used it for so many times, although it has no harm to your heater and sauna room.
- (8) After the last entry into the sauna, you should rest for at least 20 minutes. First take a shower with toilet soap and warm water, then with cold water to close your skin pores. Put on clothes when your body temperature completely cools down. (Children must be accompanied by parents for the use of sauna)

Maintenance:

- (1) It is recommended to regularly clean up the sauna, keep it ventilated, and check whether wires for electrical appliances are aging or damaged.
- (2) It is recommended to make an oil painting treatment for the sauna room every year; you can choose wood wax oil service provided by the Company when the product leaves the factory.
- (3) It is recommended to lay a carpet at the door to keep the floor clean.
- (4) In daily maintenance, it is recommended to wipe out stains to fix the sauna room with abrasive paper.
- (5) It is recommended to regularly clean up clastic sauna stones. Generally speaking, sauna stones need replacing after used for 500 hours (>500 hours).



Attention:

- (1) Don't take sauna bath after excessive eating and drinking or if you cough seriously. Patients diagnosed with serious heart disease and hypertension should pay special attention for the use of sauna.
- (2) During use, don't labber on sauna stone and any part of your body shall not touch the top of sauna stone, in case that you will be injured by the steam.
- (3) When there is a failure in electrical appliance, please stop using it and have it repaired by professionals.